



US010541381B2

(12) **United States Patent**
Park et al.

(10) **Patent No.:** **US 10,541,381 B2**
(45) **Date of Patent:** **Jan. 21, 2020**

(54) **ORGANIC LIGHT-EMITTING DEVICE AND ORGANIC LIGHT-EMITTING DISPLAY DEVICE**

(71) Applicant: **LG DISPLAY CO., LTD.**, Seoul (KR)

(72) Inventors: **Joon-Won Park**, Seoul (KR);
Moo-Chan Kang, Seoul (KR)

(73) Assignee: **LG DISPLAY CO., LTD.**, Seoul (KR)

(*) Notice: Subject to any disclaimer, the term of this patent is extended or adjusted under 35 U.S.C. 154(b) by 0 days.

(21) Appl. No.: **16/190,239**

(22) Filed: **Nov. 14, 2018**

(65) **Prior Publication Data**
US 2019/0157618 A1 May 23, 2019

(30) **Foreign Application Priority Data**
Nov. 22, 2017 (KR) 10-2017-0156596

(51) **Int. Cl.**
H01L 51/52 (2006.01)
H01L 27/32 (2006.01)

(52) **U.S. Cl.**
CPC **H01L 51/5259** (2013.01); **H01L 51/5253** (2013.01); **H01L 27/3246** (2013.01)

(58) **Field of Classification Search**
CPC . H01L 51/56; H01L 51/5012; H01L 51/0097;
H01L 27/3246; H01L 51/5072
USPC 257/40
See application file for complete search history.

(56) **References Cited**
U.S. PATENT DOCUMENTS
2016/0268540 A1* 9/2016 Kim H01L 51/5246
* cited by examiner
Primary Examiner — Andy Huynh
(74) *Attorney, Agent, or Firm* — Polsinelli PC

(57) **ABSTRACT**
Disclosed are an organic light-emitting device and an organic light-emitting display device capable of improving reliability thereof. The organic light-emitting device or the organic light-emitting display device includes an organic encapsulation layer disposed on a light-emitting element, and the organic encapsulation layer includes a first organic encapsulation layer disposed on an inorganic encapsulation layer and a second organic encapsulation layer disposed so as to surround the first organic encapsulation layer and including a moisture-absorbent material. As such, it is possible to achieve a reduction in cost and to prevent moisture or oxygen from being introduced from the outside into the side surface of the organic light-emitting device.

20 Claims, 8 Drawing Sheets

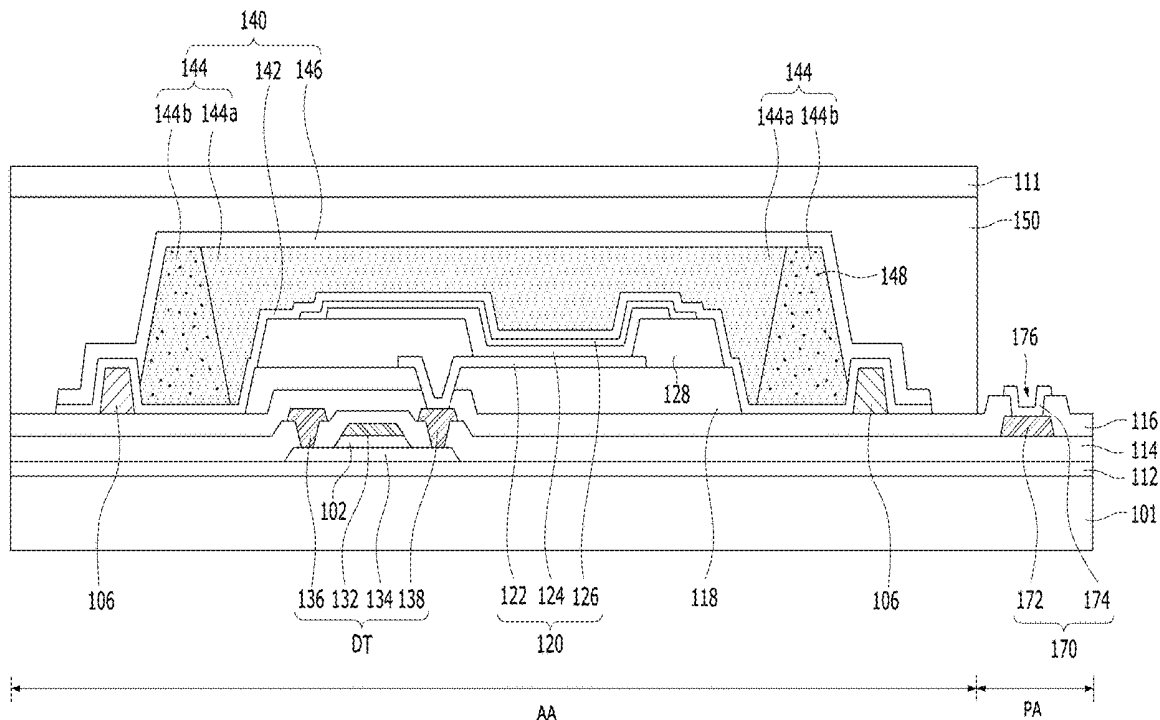

FIG. 1

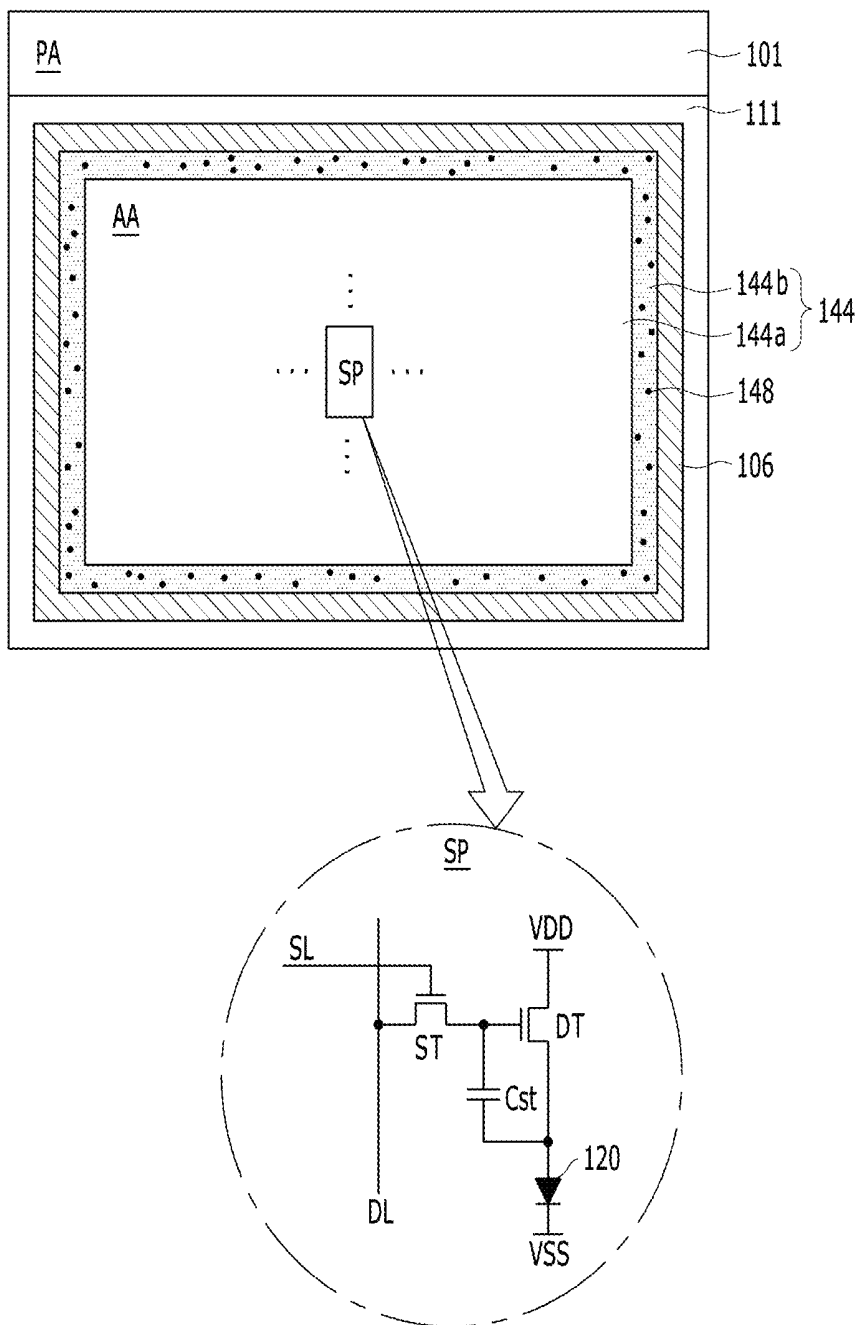

FIG. 2

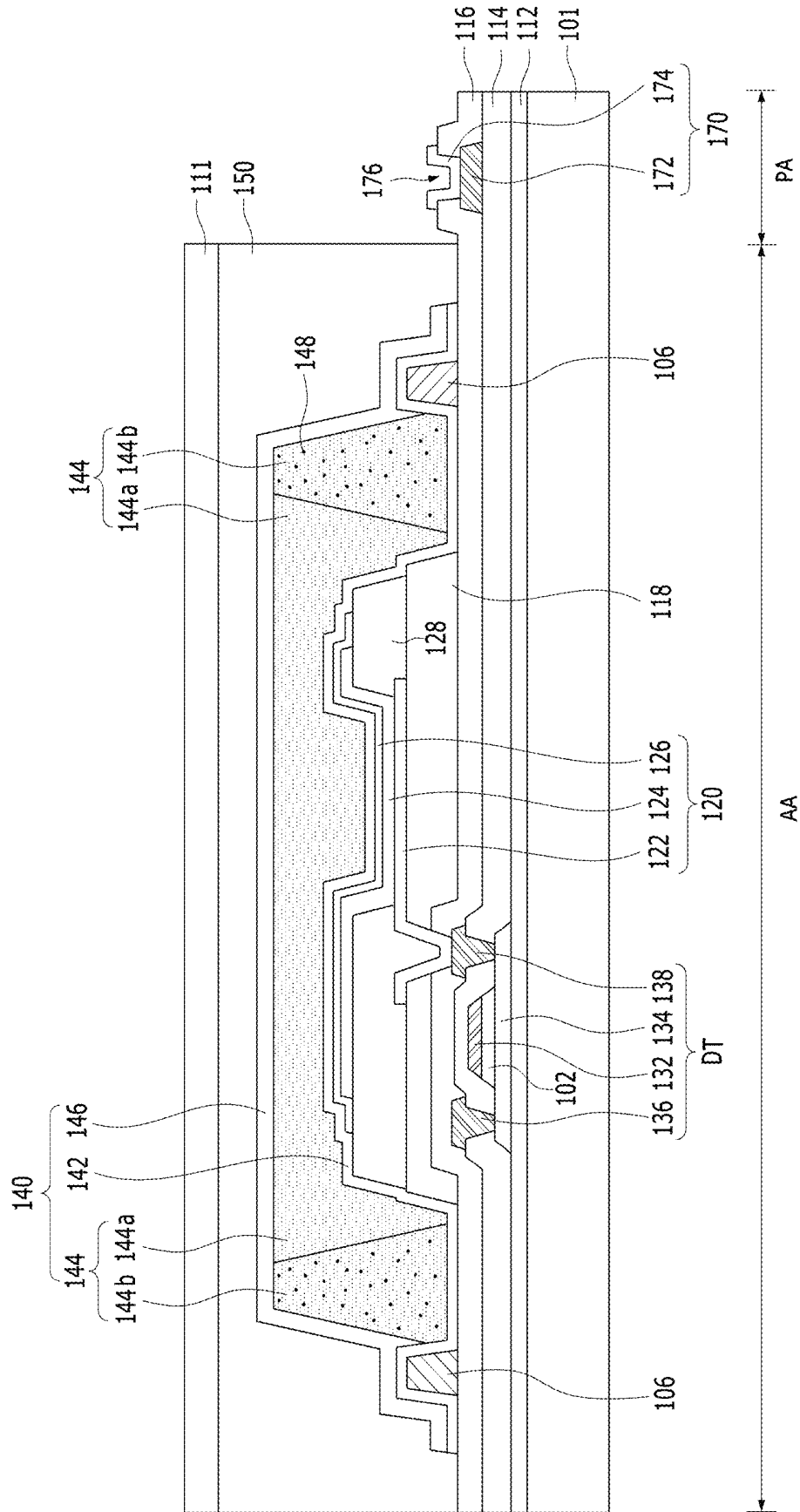

FIG. 3A

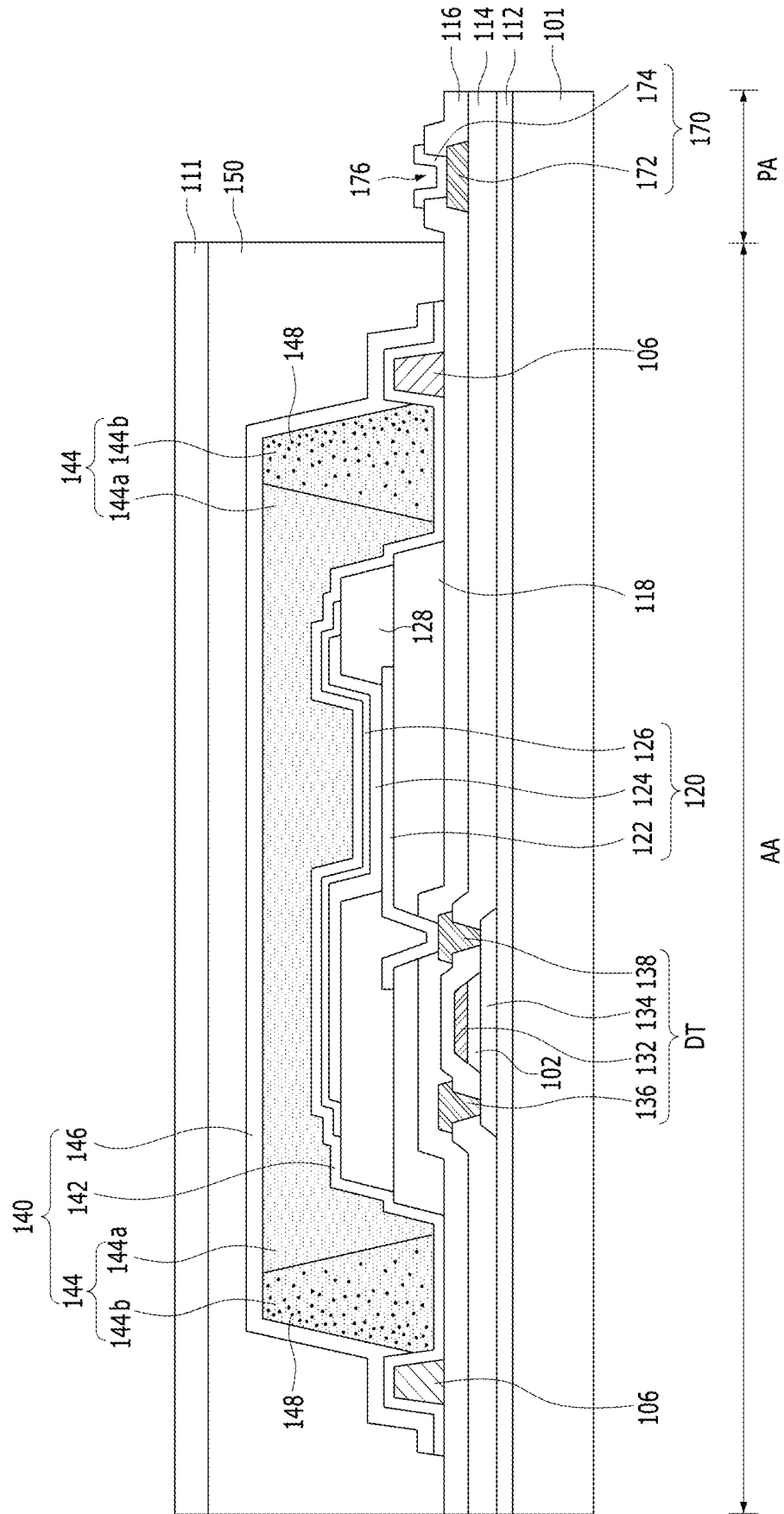

FIG. 3B

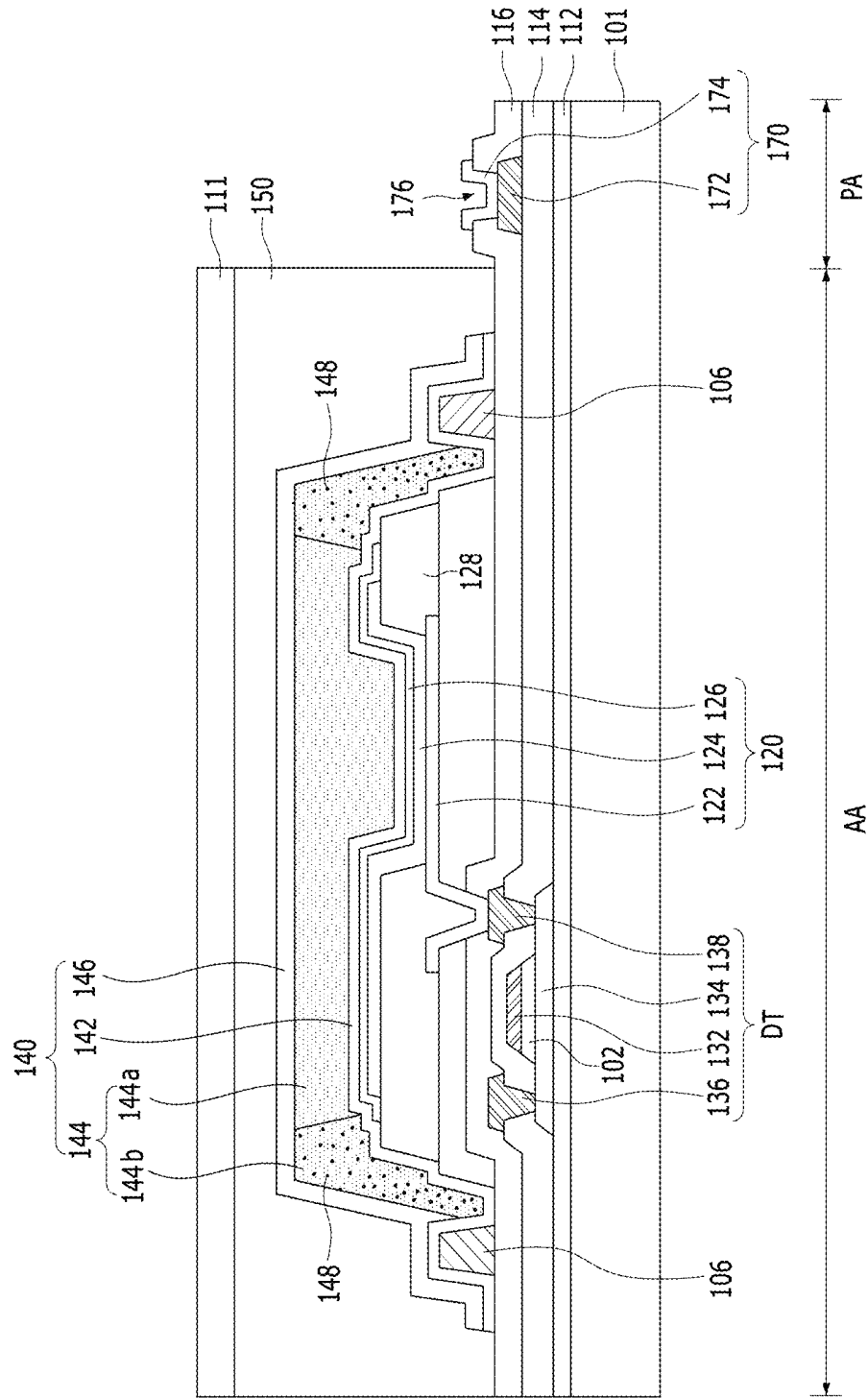

FIG. 4A

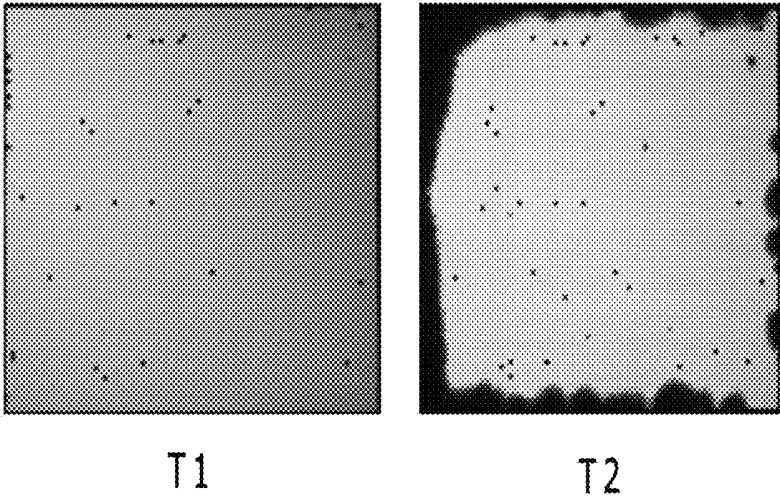

FIG. 4B

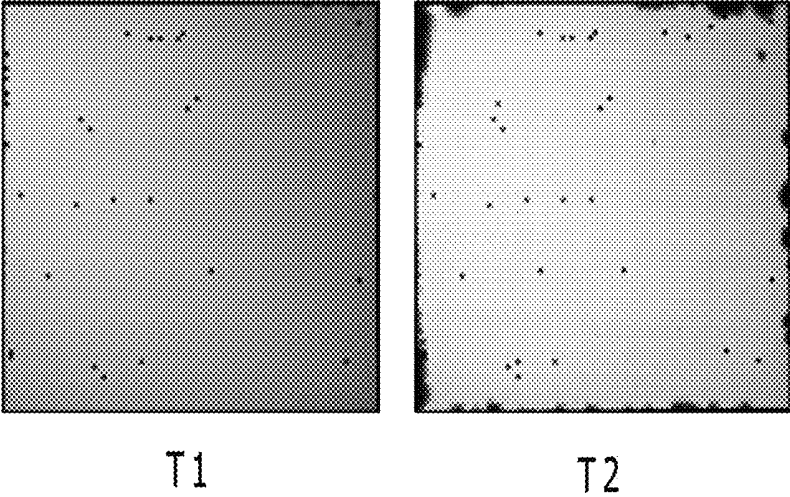

FIG. 5A

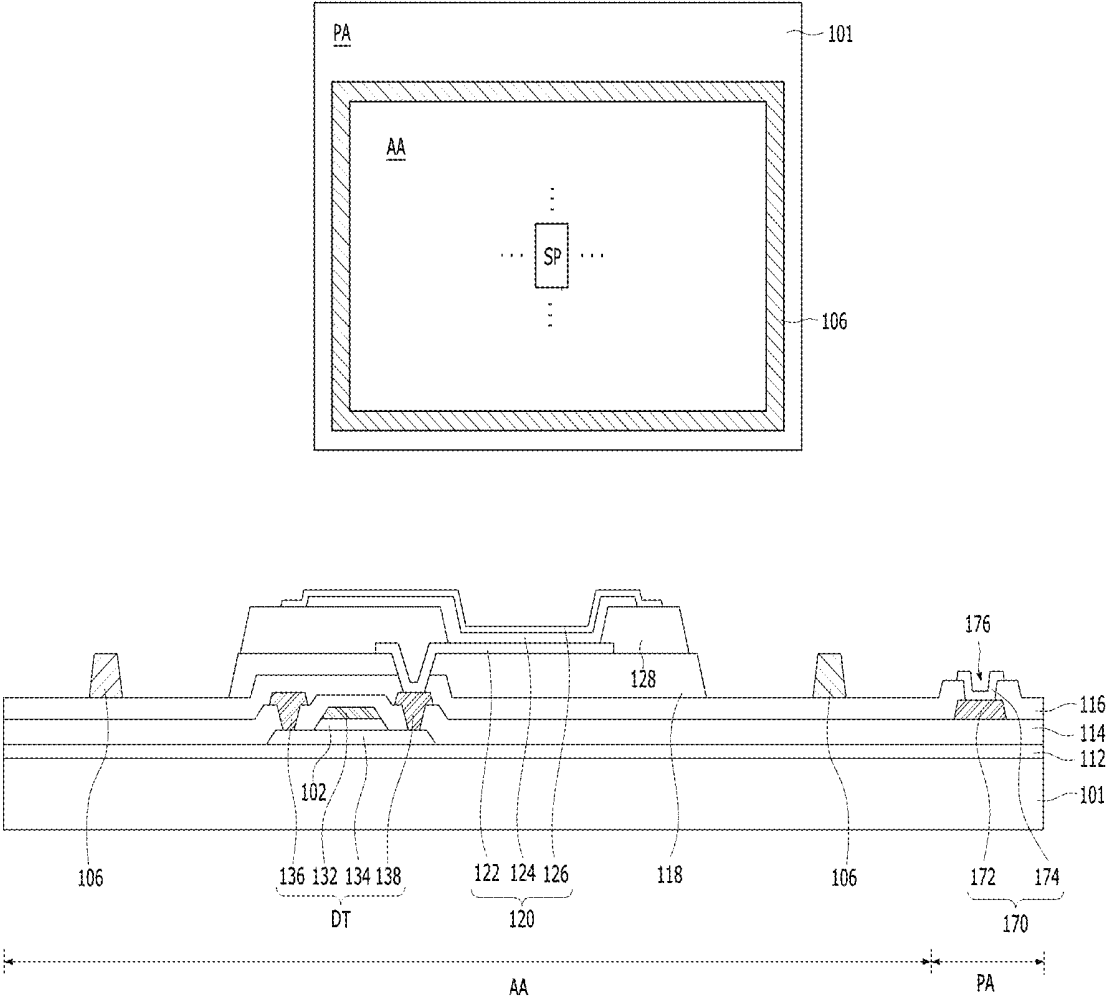

FIG. 5B

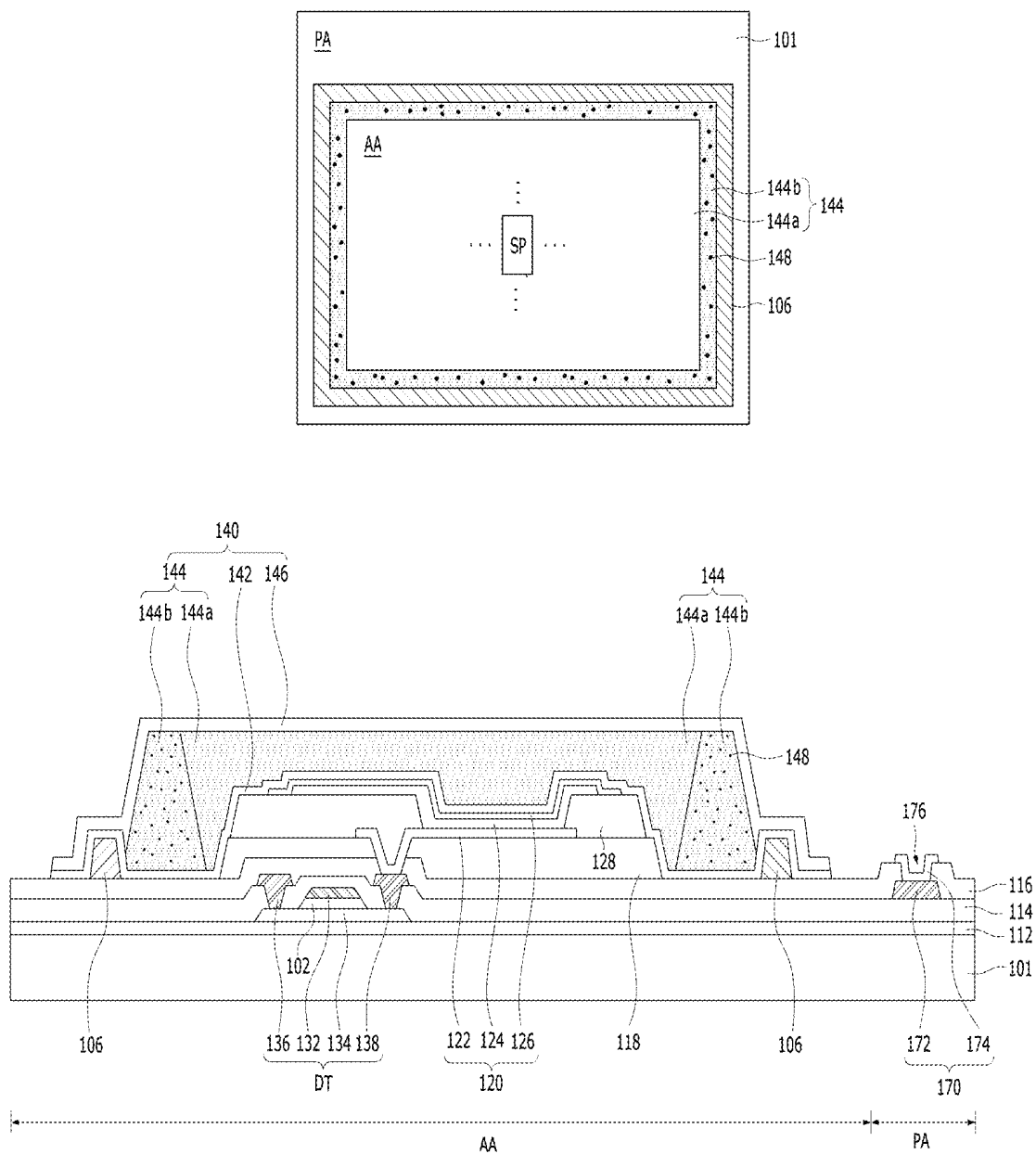
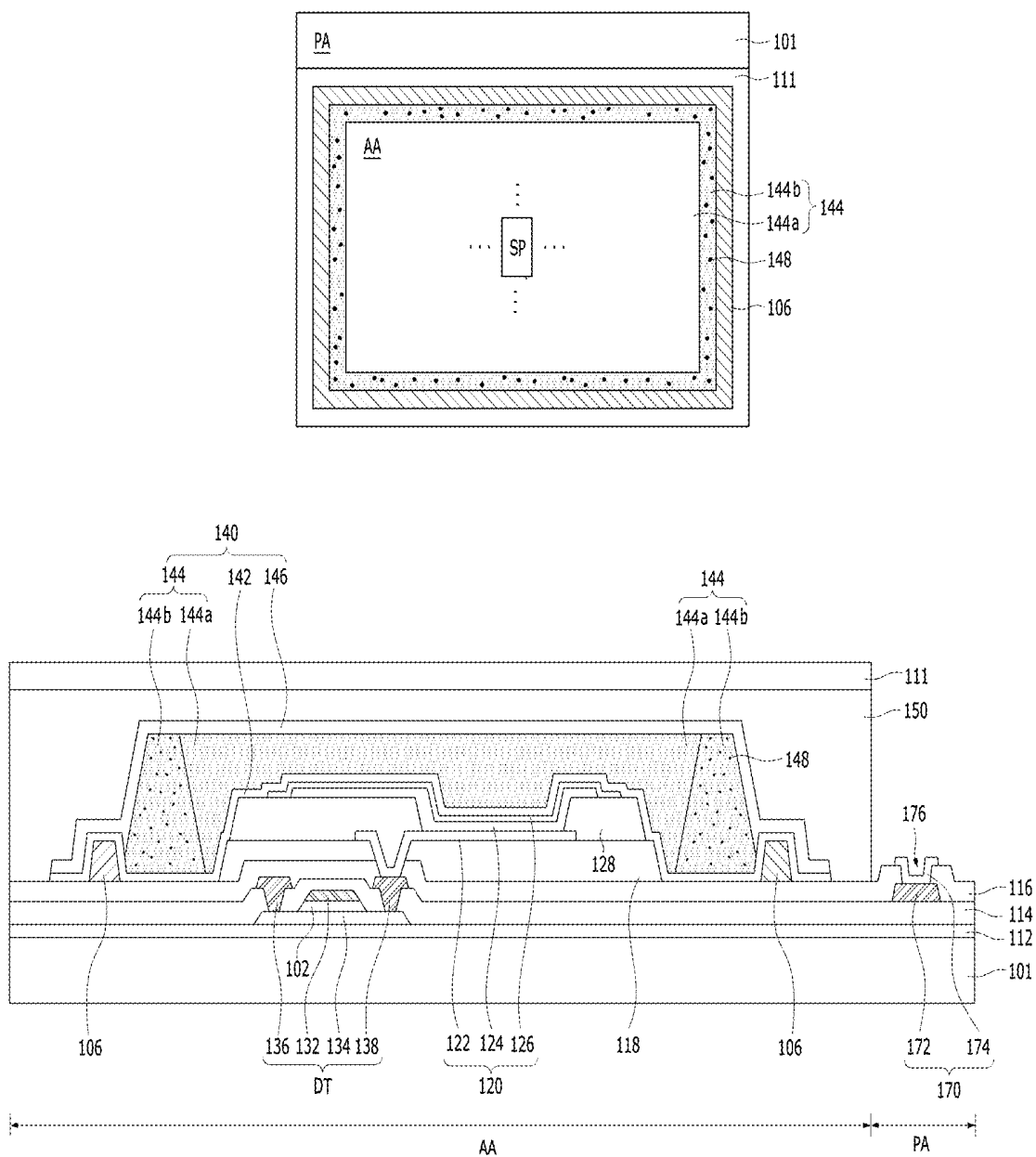

FIG. 5C



ORGANIC LIGHT-EMITTING DEVICE AND ORGANIC LIGHT-EMITTING DISPLAY DEVICE

CROSS REFERENCE TO RELATED APPLICATION

This application claims the benefit of Korean Patent Application No. 10-2017-0156596, filed on Nov. 22, 2017, which is hereby incorporated by reference in its entirety as if fully set forth herein.

BACKGROUND

Field of the Disclosure

The present disclosure relates to an organic light-emitting device and organic light-emitting display device, and more particularly, to an organic light-emitting device and an organic light-emitting display device, which are capable of improving the reliability thereof.

Description of the Background

An organic light-emitting device (OLED) is a self-illuminating device and does not require a separate light source, and therefore can be manufactured to have a light and thin profile. In addition, an organic light-emitting device is advantageous in power consumption due to the low-voltage driving thereof, and is excellent in a color implementation, a response speed, a color viewing angle, and a contrast ratio (CR), and therefore has been studied as a next-generation light-emitting device.

An organic material and a metal material, which are included in such an organic light-emitting device, are easily oxidized by external factors, such as moisture (H₂O) and oxygen (O₂). In particular, when adhesion between a plurality of thin-film layers included in the organic light-emitting device is poor, moisture or oxygen is introduced into an organic layer disposed between an anode electrode and a cathode electrode. When the organic layer is degenerated by the moisture or oxygen, a pixel shrinkage defect, by which each subpixel is blackened from the edge thereof, can occur. In addition, when the pixel shrinkage defect can continuously occur for a long time, this is worsened to become a dark spot defect, by which the entire subpixel area can be blackened, which deteriorates the reliability of the organic light-emitting device.

SUMMARY

Accordingly, the present disclosure is directed to an organic light-emitting device and an organic light-emitting display device that substantially obviate one or more problems due to limitations and disadvantages of the related art.

More specifically, the present disclosure has been provided to solve the problems described above, and the present disclosure is to provide an organic light-emitting device and an organic light-emitting display device, which are capable of improving the reliability thereof.

Additional advantages and features of the disclosure will be set forth in part in the description which follows and in part will become apparent to those having ordinary skill in the art upon examination of the following or may be learned from practice of the disclosure. Other advantages of the disclosure may be realized and attained by the structure

particularly pointed out in the written description and claims hereof as well as the appended drawings.

To achieve these and other advantages and in accordance with the purpose of the disclosure, as embodied and broadly described herein, an organic light-emitting device or an organic light-emitting display device includes an organic encapsulation layer disposed on a light-emitting element, and the organic encapsulation layer includes a first organic encapsulation layer disposed on an inorganic encapsulation layer and a second organic encapsulation layer disposed so as to surround the first organic encapsulation layer and including a moisture-absorbent material. As such, it is possible to achieve a reduction in cost and to prevent moisture or oxygen from being introduced from the outside into the side surface of the organic light-emitting device.

In another aspect of the present disclosure, an organic light-emitting device having a substrate where an active area and non-active area are defined, includes an organic light-emitting element disposed at the active area; a first inorganic encapsulation layer disposed on the organic light-emitting element; an organic encapsulation layer disposed on the first inorganic encapsulation layer; and a moisture absorbing layer preventing external moisture from penetrating into lateral sides of the organic light-emitting device and surrounding the first organic encapsulation layer.

It is to be understood that both the foregoing general description and the following detailed description of the present disclosure are exemplary and explanatory and are intended to provide further explanation of the disclosure as claimed.

BRIEF DESCRIPTION OF THE DRAWINGS

The accompanying drawings, which are included to provide a further understanding of the disclosure and are incorporated in and constitute a part of this application, illustrate aspect(s) of the disclosure and together with the description serve to explain the principle of the disclosure.

In the drawings:

FIG. 1 is a view illustrating an organic light-emitting device according to the present disclosure;

FIG. 2 is a cross-sectional view illustrating the organic light-emitting device of FIG. 1;

FIGS. 3A and 3B are cross-sectional views illustrating other aspects of the organic light-emitting device according to the present disclosure;

FIGS. 4A and 4B are views illustrating experimental results of the reliability of organic light-emitting devices according to a comparative example and an example of the present disclosure; and

FIGS. 5A to 5C are views for explaining a method of manufacturing the organic light-emitting device illustrated in FIG. 2.

DETAILED DESCRIPTION

Hereinafter, exemplary aspects according to the present disclosure will be described in detail with reference to the accompanying drawings.

An organic light-emitting device, illustrated in FIGS. 1 and 2, includes first and second substrates **101** and **111**, which face each other with an organic light-emitting element **120** interposed therebetween.

The first substrate **101** is configured with a glass or plastic substrate having moisture permeation preventing ability. When the first substrate **101** is a plastic substrate, it may be

formed of a polyimide-based material or a polycarbonate-based material and may be flexible.

The second substrate **111** is disposed so as to face the first substrate **101**. The second substrate **111** is formed to have a size smaller than that of the first substrate **101** and exposes a pad area PA formed in the first substrate **101**.

The second substrate **111** is formed of glass, metal, or the like, depending on the direction in which the organic light-emitting device emits light. For example, when the organic light-emitting device has a bottom-emission structure, the second substrate **111** is formed of opaque metal, for example. When the organic light-emitting device has a top-emission structure, the second substrate **111** is formed of transparent glass, for example. The second substrate **111** described above serves to block moisture or oxygen introduced from the outside to the top of the organic light-emitting device.

The first and second substrates **101** and **111** are attached to each other using an adhesive layer **150**, which is applied on the entire surface of at least one of the first substrate **101** or the second substrate **111**.

The organic light-emitting device, having the first and second substrates **101** and **111** described above, may be defined as an active area AA and the pad area PA.

The pad area PA is provided with a plurality of pads **170**, which supplies driving signals to each of a scan line SL, a data line DL, a low-voltage (VSS) supply line, and a high-voltage (VDD) supply line, which are located in the active area AA. The pads **170** are exposed by the second substrate **111**, which is formed so as to over the active area AA. Each of the pads **170** includes a pad electrode **172** and a pad cover electrode **174**.

The pad electrode **172** is formed of the same material as at least one of a gate electrode **132** or a source electrode **136**. The pad electrode **172** is connected to a signal line including the scan line SL, the data line DL, the low-voltage (VSS) supply line, and the high-voltage (VDD) supply line, which are located in the active area AA.

The pad cover electrode **174** is electrically connected to the pad electrode **172**, which is exposed through a pad contact hole **176** formed in a protective layer **116**. In addition, the pad cover electrode **174** is exposed outwards so as to come into contact with a circuit transmission film, which is connected to a drive circuit. Here, since the pad cover electrode **174** is formed of a metal having high corrosion resistance and acid resistance, it is possible to prevent the pad cover electrode **174** from being corroded by external moisture or the like even when it is exposed outwards by the second substrate **111**. For example, the pad cover electrode **174** is formed on the protective layer **116** using the same material as at least one of an anode electrode **122** and a cathode electrode **126**. That is, the pad cover electrode **174** is formed of a transparent conductive layer, such as indium-tin-oxide (ITO) and indium-zinc-oxide (IZO), which has high corrosion resistance and acid resistance.

The active area AA is an area in which a plurality of subpixels SP is arranged in a matrix form. Each subpixel SP includes a pixel drive circuit and the organic light-emitting element **120**.

The pixel drive circuit includes a switching transistor ST, a driving transistor DT, and a capacitor Cst. Here, the configuration of the pixel drive circuit is not limited to the structure of FIG. 1, and any of various configurations of pixel drive circuits may be used.

The switching transistor ST is turned on under control of the scan line SL to transmit a data voltage from the data line DL to a gate electrode of the driving transistor DT.

The storage capacitor Cst is connected to both a scan terminal of the driving transistor DT and the low-voltage (VSS) supply line to charge a differential voltage therebetween so as to transmit the same as a driving voltage of the driving transistor DT.

The driving transistor DT is switched in response to a data signal supplied from the switching transistor ST to control current flowing from the high-voltage (VDD) supply line to the organic light-emitting element **120**. The driving thin-film transistor DT, as illustrated in FIG. 2, includes a semiconductor layer **134** disposed on a buffer layer **112**, the gate electrode **132** disposed to overlap the semiconductor layer **134** with a gate insulation layer **102** interposed therebetween, and source and drain electrodes **136** and **138**, which are formed on an interlayer insulation layer **114** so as to come into contact with the semiconductor layer **134**. Here, the semiconductor layer **134** is formed of at least one of an amorphous semiconductor material, a polycrystalline semiconductor material, and an oxide semiconductor material.

The organic light-emitting element **120** is located between a source terminal of the driving transistor DT and the low-voltage (VSS) supply line and is electrically connected thereto to emit light using current, which corresponds to the data signal supplied from the driving transistor DT. To this end, the organic light-emitting element **120** includes the anode electrode **122** connected to the source terminal of the driving transistor DT, an organic layer **124** formed on the anode electrode **122**, and the cathode electrode **126** formed on the organic layer **124**.

The anode electrode **122** is electrically connected to the drain electrode **138** of the driving thin-film transistor DT, which is exposed through a pixel contact hole formed in the protective layer **116** and a pixel planarization layer **118**.

The organic layer **124** is formed on the anode electrode **122** in a light-emitting area defined by a bank **128**. The organic layer **124** may include a hole injection layer, a hole transport layer, an emission layer, an electron transport layer, and an electron injection layer.

The cathode electrode **126** is formed so as to face the anode electrode **122** with the organic layer **124** interposed therebetween, and is connected to the low-voltage (VSS) supply line. When the organic light-emitting device, including the cathode electrode **126**, the organic layer **124**, and the anode electrode **122**, has a top-emission structure, the cathode electrode **126** is formed of a transparent conductive layer, such as indium-tin-oxide (ITO) or indium-zinc-oxide (IZO), and the anode electrode **122** is formed of an opaque conductive layer, which is formed in a single layer or in multiple layers using Al, Ag, Cu, Pb, Mo, Ti, or an alloy thereof. For example, the anode electrode **122** takes the form of a stack including a transparent conductive layer, an opaque conductive layer, and a transparent conductive layer, which are sequentially stacked. In addition, when the organic light-emitting device has a bottom-emission structure, the anode electrode **122** is formed of a transparent conductive layer, and the cathode electrode **126** is formed in a single layer or in multiple layers using an opaque conductive layer.

An encapsulation stack **140** prevents external moisture or oxygen from being introduced into the organic light-emitting element **120**, which is vulnerable to external moisture or oxygen. To this end, the encapsulation stack **140** includes a plurality of inorganic encapsulation layers **142** and **146** and an organic encapsulation layer **144** disposed between the

inorganic encapsulation layers **142** and **146**, and the inorganic encapsulation layer **146** is disposed in the uppermost layer. Here, the encapsulation stack **140** includes at least two inorganic encapsulation layers **142** and **146** and at least one organic encapsulation layer **144**. In the present disclosure, the structure of the encapsulation stack **140** in which the organic encapsulation layer **144** is disposed between first and second inorganic encapsulation layers **142** and **146** will be described by way of example.

The first inorganic encapsulation layer **142** is formed on the first substrate **101**, on which the cathode electrode **126** is formed, so as to be closest to the organic light-emitting element **120**. The first inorganic encapsulation layer **142** is formed of an inorganic insulation material that enables low-temperature deposition, such as silicon nitride (SiNx), silicon oxide (SiOx), silicon oxide nitride (SiON), and aluminum oxide (Al₂O₃). Thereby, since the first inorganic encapsulation layer **142** is deposited under a low-temperature atmosphere, it is possible to prevent damage to the organic layer **124**, which is vulnerable to a high-temperature atmosphere during deposition of the first inorganic encapsulation layer **142**.

The organic encapsulation layer **144** includes a first organic encapsulation layer **144a** and a second organic encapsulation layer **144b** disposed so as to surround the first organic encapsulation layer **144a**.

The first organic encapsulation layer **144a** is disposed on the first inorganic encapsulation layer **142** so as to have an area smaller than that of the first inorganic encapsulation layer **142**. The first organic encapsulation layer **144a** is formed of an organic insulation material such as acryl resin, epoxy resin, polyimide, polyethylene, and silicon oxycarbon (SiOC). Thereby, the first organic encapsulation layer **144a** serves to alleviate stress between the respective layers caused by repetitive bending of the organic light-emitting device, and increases planarization performance.

The second organic encapsulation layer **144b** is located outside the first organic encapsulation layer **144a** and is formed so as to surround the first organic encapsulation layer **144a**. The second organic encapsulation layer **144b** includes a moisture-absorbent material **148** in order to adsorb or remove moisture, oxygen or the like introduced into the side surface of the organic light-emitting device. That is, the second organic encapsulation layer **144b** includes the organic insulation material and the moisture-absorbent material **148**.

The organic insulation material of the second organic encapsulation layer **144b** may be formed of the same material as or a different material from the organic insulation material of the first organic encapsulation layer **144a**. For example, the second organic encapsulation layer **144b** may be formed of acryl resin, epoxy resin, polyimide, polyethylene, or silicon oxycarbon (SiOC).

The moisture-absorbent material **148** may include a moisture-absorbent material such as silica including hollow silica, zeolite, titania, zirconia, or montmorillonite, a metal salt, and a metal oxide, or the like alone, or a mixture of two or more ones thereof.

Here, the metal oxide may include a metal oxide such as lithium oxide (Li₂O), sodium oxide (Na₂O), barium oxide (BaO), calcium oxide (CaO), and magnesium oxide (MgO), an organic metal oxide, phosphorous pentoxide (P₂O₅), or the like alone or a mixture of two or more ones thereof.

In addition, the metal salt includes a sulfate such as lithium sulfate (Li₂SO₄), sodium sulfate (Na₂SO₄), calcium sulfate (CaSO₄), magnesium sulfate (MgSO₄), cobalt sulfate (CoSO₄), gallium sulfate (Ga₂(SO₄)₃), titanium sulfate (Ti

(SO₄)₂), or nickel sulfate (NiSO₄), a metal halide such as calcium chloride (CaCl₂), magnesium chloride (MgCl₂), strontium chloride (SrCl₂), yttrium chloride (YCl₃), copper chloride (CuCl₂), cesium fluoride (CsF), tantalum fluoride (TaF₅), niobium fluoride (NbF₅), lithium bromide (LiBr), calcium bromide (CaBr₂), cesium bromide (CeBr₃), selenium bromide (SeBr₄), vanadium bromide (VBr₃), magnesium bromide (MgBr₂), barium iodide (BaI₂), or magnesium iodide (MgI₂), a metal perchlorate such as barium perchlorate (Ba(ClO₄)₂) and magnesium perchlorate (Mg(ClO₄)₂), or the like alone, or a mixture of two or more ones thereof. The moisture-absorbent material **148** is not limited to the above-described exemplary materials.

As described above, in the present disclosure, the moisture-absorbent material **148** is included in the second organic encapsulation layer **144b**, which is disposed closer to a dam **106** than the first organic encapsulation layer **144a**. Here, external moisture, oxygen, or the like is not introduced through the first and second substrates **101** and **111**, which are formed of an inorganic material, but is introduced through the adhesive layer **150**, which is formed of an organic material. Dark spots, which are generated due to external moisture or oxygen introduced through the adhesive layer **150**, are not visible from the central portion of the organic light-emitting device, but are visible only through the side surface of the organic light-emitting device to thereby be diffused. Therefore, in the present disclosure, the moisture-absorbent material **148** is included only in the second organic encapsulation layer **144b**, rather than in the first organic encapsulation layer **144a**, which is located in the central portion of the organic light-emitting device. Thereby, the organic light-emitting device of the present disclosure may prevent dark spots from becoming visible due to external moisture, oxygen, or the like introduced through the side surface thereof and may reduce the amount of use of the moisture-absorbent material **148**, which is expensive, which may result in a reduction in cost.

The moisture-absorbent material **148** of the second organic encapsulation layer **144b** described above, as illustrated in FIG. 2, is uniformly formed in the second organic encapsulation layer **144b**. Alternatively, as illustrated in FIG. 3A, the density of the moisture-absorbent material **148** may gradually increase from the side surface of the first organic encapsulation layer **144a** toward the side surface of the dam **106**. In this case, since the amount of the moisture-absorbent material **148** increases with decreasing distance to the outer surface of the organic light-emitting device, it is possible to effectively prevent the introduction of external moisture, oxygen, or the like.

The structure in which the second organic encapsulation layer **144b** is disposed between the bank **128** and the dam **106** has been described above with reference to FIG. 2 by way of example. The second organic encapsulation layer **144b**, which is disposed between the bank **128** and the dam **106** as illustrated in FIG. 2, may be applied both to the top-emission-type organic light-emitting device and to the bottom-emission-type organic light-emitting device. When the second organic encapsulation layer **144b** is applied to the top-emission-type organic light-emitting device in which light is emitted from the second substrate **111**, in order to prevent a reduction in aperture ratio due to the second organic encapsulation layer **144b**, the second organic encapsulation layer **144b** is not formed in the light-emitting area in which the organic light-emitting element **120** is disposed, but is formed in a bezel area that surrounds the active area AA. Here, a scan drive unit for driving the scan line SL or the like is disposed in the bezel area. In addition, when the

second organic encapsulation layer **144b** is applied to the bottom-emission-type organic light-emitting device in which light is emitted from the first substrate **101**, the second organic encapsulation layer **144b** is formed in at least one of the bezel area or the light-emitting area in which the organic light-emitting element **120** is disposed. For example, the second organic encapsulation layer **144** may be formed so as to overlap the bank **128** of outermost subpixels, as illustrated in FIG. 3B, or may be formed so as to overlap the organic layer **124** and the bank of outermost subpixels.

When the organic encapsulation layer **144**, including the first and second organic encapsulation layers **144a** and **144b**, is formed by an inkjet method, the dam **106** is disposed in order to prevent the organic encapsulation layer **144** in a liquid form from being diffused to the edge of the substrate **111**. That is, the dam **106** is disposed so as to surround the second organic encapsulation layer **144b**. Through the provision of the dam **106**, it is possible to prevent the organic encapsulation layer **144** from being diffused to the outermost pad area PA of the substrate **111** in which the signal pads **170** are disposed. To this end, the dam **106** may be formed so as to fully surround the active area AA in which the organic light-emitting element **120** is disposed, as illustrated in FIG. 1, or may be formed only between the active area AA and the pad area PA. In the present disclosure, the structure in which a single dam **106** is provided to surround the active area AA, as illustrated in FIGS. 1 and 2, has been described by way of example, but a plurality of dams may be spaced apart from each other by a predetermined distance and may be arranged parallel to each other.

The dam **106** is formed in a single layer or in multiple layers. For example, the dam **106** is formed simultaneously with at least one of the bank **128** or a spacer (not illustrated) using the same material, which may obviate an additional mask process and prevent an increase in cost.

The second inorganic encapsulation layer **146** is formed on the substrate **111** having the organic encapsulation layer **144** formed thereon, so as to cover the upper surface and the side surface of the organic encapsulation layer **144**. Thereby, the second inorganic encapsulation layer **146** minimizes or prevents external moisture or oxygen from being introduced into the first inorganic encapsulation layer **142** and the organic encapsulation layer **144**. The second inorganic encapsulation layer **142** is formed of an inorganic insulation material, such as silicon nitride (SiNx), silicon oxide (SiOx), silicon oxide nitride (SiON), and aluminum oxide (Al₂O₃).

As described above, in the organic light-emitting device of the present disclosure, the second organic encapsulation layer **144b** including the moisture-absorbent material **148** is disposed so as to surround the side surface of the active area AA, and the second substrate **111** is formed of glass or a metal material. Thereby, the second organic encapsulation layer **144b** of the present disclosure prevents moisture or oxygen from being introduced from the outside into the side surface of the organic light-emitting device, and the second substrate **111** prevents moisture or oxygen from being introduced from the outside into the upper surface of the organic light-emitting device, which results in improved reliability.

FIGS. 4A and 4B are views illustrating experimental results of reliability according to a comparative example in which an organic encapsulation layer includes no moisture-absorbent material and according to an example of the present disclosure in which an organic encapsulation layer includes a moisture-absorbent material.

In the case of the comparative example having no moisture-absorbent material, as illustrated in FIG. 4A, it can be appreciated that, when the organic light-emitting device is

used for a predetermined amount of time (from T1 to T2), dark spots are rapidly diffused from the side surface to the central portion of the organic light-emitting device. On the other hand, in the case of the example in which the second organic encapsulation layer **144b** includes the moisture-absorbent material **148**, it can be appreciated that, when the organic light-emitting device is used for a predetermined amount of time (from T1 to T2), dark spots are diffused from the side surface to the central portion of the organic light-emitting device, but the diffusion rate of dark spots is slower than that in the comparative example.

In this way, in the example of the present disclosure, the moisture-absorbent material **148** in the second organic encapsulation layer **144b** may adsorb or remove moisture, oxygen, or the like introduced from the side surface of the organic light-emitting device, thereby being capable of reducing the diffusion rate of dark spots, compared to that in the comparative example. Thereby, it can be appreciated that the present disclosure achieves improved reliability compared to the comparative example.

FIGS. 5A to 5C are views for explaining a method of manufacturing the organic light-emitting device according to the present disclosure.

First, as illustrated in FIG. 5A, the thin-film transistors ST and DT having the active layer **134**, the organic light-emitting element **120**, the dam **106**, and the signal pad **170** are formed on the first substrate **101** through a plurality of mask processes.

Subsequently, as illustrated in FIG. 5B, the first inorganic encapsulation layer **142** is formed on the substrate **101** having the organic light-emitting element **120** formed thereon by a deposition method, such as chemical vapor deposition (CVD), low pressure chemical vapor deposition (LPCVD), or plasma enhanced chemical vapor deposition (PECVD). Here, the first inorganic encapsulation layer **142** is formed of SiOx, SiNx, or SiON. Subsequently, an organic insulation material is coated over the first substrate **101** having the first inorganic encapsulation layer **142** formed thereon so as to form the first organic encapsulation layer **144a**, and thereafter an organic insulation material including the moisture-absorbent material **148** is coated to surround the first organic encapsulation layer **144** so as to form the second organic encapsulation layer **144b**. Here, the organic insulation material of the first and second organic encapsulation layers **144a** and **144b** may be acryl resin, epoxy resin, polyimide, polyethylene, or silicon oxycarbon (SiOC). Although the method of forming the second organic encapsulation layer **144b** after the first organic encapsulation layer **144a** is formed has been described above by way of example, the second organic encapsulation layer **144b** may first be formed, and thereafter, the first organic encapsulation layer **144a** may be formed by an inkjet method. In this case, the side surface of the second organic encapsulation layer **144b** may be tapered at an acute angle, and the side surface of the first organic encapsulation layer **144a** may be inversely tapered at an obtuse angle.

Subsequently, when the second inorganic encapsulation layer **146** is formed on the first substrate **101** having the organic encapsulation layer **144** formed thereon through the above-described deposition process, the encapsulation stack **140** having a multilayer structure is formed.

Subsequently, after the adhesive layer **150** is transferred to at least one of the first substrate **101** having the encapsulation stack **140** formed thereon or the second substrate **111**, as illustrated in FIG. 5C, the second substrate **111** is heated and is compressed onto the first substrate **101** having the encapsulation stack **140** formed thereon. Thereby, the first

and second substrates **101** and **111** are attached to each other via the adhesive layer **150**, whereby the organic light-emitting device is completed.

Although the organic light-emitting device, which includes a pixel drive circuit for each subpixel SP and is driven in an active matrix manner, has been described in the present disclosure by way of example, the present disclosure may also be applied to an organic light-emitting device, which is driven in a passive matrix manner without a pixel drive circuit for each subpixel SP.

In addition, the organic light-emitting device of the present disclosure may be applied to various fields including a lighting apparatus or a display device that displays an image.

As is apparent from the above description, according to the aspects of the present disclosure, a second organic encapsulation layer including a moisture-absorbent material is disposed so as to surround a first organic encapsulation layer, and a second substrate is formed of glass or a metal material having moisture permeation preventing ability. Thereby, the second organic encapsulation layer of the present disclosure prevents moisture or oxygen from being introduced from the outside into the side surface of an organic light-emitting device, and the second substrate prevents moisture or oxygen from being introduced from the outside into the upper surface of the organic light-emitting device, which results in improved reliability. In addition, in the present disclosure, the moisture-absorbent material is included only in the second organic encapsulation layer, other than the first organic encapsulation layer located in the central portion of the organic light-emitting device. Thereby, the organic light-emitting device of the present disclosure may prevent dark spots from becoming visible due to external moisture, oxygen, or the like introduced through the side surface thereof and may reduce the amount of use of the moisture-absorbent material, which is expensive, which may result in a reduction in cost.

Although the aspects of the present disclosure have been described above in detail with reference to the accompanying drawings, it will be apparent to those skilled in the art that the present disclosure described above is not limited to the aspects described above, and various substitutions, modifications, and alterations may be devised within the spirit and scope of the present disclosure. Thus, the aspects disclosed in the specification of the present disclosure are not intended to limit the present disclosure, and the technical scope of the present disclosure should be interpreted based on the following claims, and all technical ideas that fall within the range equivalent to the claims should be understood as belonging to the scope of the present disclosure.

What is claimed is:

1. An organic light-emitting device comprising:

a light-emitting element disposed on an active area of a substrate; and

an encapsulation stack disposed on the light-emitting element and including a plurality of inorganic encapsulation layers and at least one organic encapsulation layer disposed between the inorganic encapsulation layers,

wherein the at least one organic encapsulation layer includes:

a first organic encapsulation layer disposed on the plurality of inorganic encapsulation layers; and

a second organic encapsulation layer surrounding the first organic encapsulation layer and including a moisture-absorbent material dispersed in the second organic encapsulation layer.

2. The device according to claim **1**, further comprising a dam surrounding the second organic encapsulation layer.

3. The device according to claim **2**, wherein the second organic encapsulation layer is disposed between the dam and the first organic encapsulation layer.

4. The device according to claim **2**, wherein the moisture-absorbent material is gradually increased in density from a side surface of the first organic encapsulation layer to a side surface of the dam.

5. The device according to claim **1**, wherein the light-emitting element comprises:

an anode electrode disposed on the substrate;

a cathode electrode facing the anode electrode; and

an organic layer disposed between the anode electrode and the cathode electrode, and

wherein the second organic encapsulation layer overlaps a bank defining a light-emitting area of the organic layer, or overlaps the bank and the organic layer.

6. An organic light-emitting display device comprising:

a thin film transistor on a substrate;

a light-emitting element disposed on an active area of the substrate and connected to the thin film transistor; and an encapsulation stack disposed on the light-emitting element and including a plurality of inorganic encapsulation layers and at least one organic encapsulation layer disposed between the inorganic encapsulation layers,

wherein the at least one organic encapsulation layer includes:

a first organic encapsulation layer disposed on the inorganic encapsulation layer; and

a second organic encapsulation layer surrounding the first organic encapsulation layer and including a moisture-absorbent material dispersed in the second organic encapsulation layer.

7. The display device according to claim **6**, further comprising a dam surrounding the second organic encapsulation layer.

8. The display device according to claim **7**, wherein the second organic encapsulation layer is disposed between the dam and the first organic encapsulation layer.

9. The display device according to claim **7**, wherein the moisture-absorbent material is gradually increased in density from a side surface of the first organic encapsulation layer to a side surface of the dam.

10. The display device according to claim **6**, wherein the light-emitting element comprises:

an anode electrode disposed on the substrate;

a cathode electrode disposed so as to face the anode electrode; and

an organic layer disposed between the anode electrode and the cathode electrode, and

wherein the second organic encapsulation layer overlaps a bank defining a light-emitting area of the organic layer, or overlaps the bank and the organic layer.

11. An organic light-emitting device having a substrate where an active area and non-active area are defined, comprising:

an organic light-emitting element disposed at the active area;

a first inorganic encapsulation layer disposed on the organic light-emitting element;

a first organic encapsulation layer disposed on the first inorganic encapsulation layer; and

11

a moisture absorbing layer preventing external moisture from penetrating into lateral sides of the organic light-emitting device and surrounding the first organic encapsulation layer,

wherein the moisture absorbing layer is a second organic encapsulating layer including a moisture-adsorbent material dispersed in the second organic encapsulation layer.

12. The device according to claim **11**, further comprising a dam surrounding the moisture absorbing layer and preventing the moisture and oxygen absorbing layer from spreading out.

13. The device according to claim **12**, wherein the moisture absorbing layer is formed of a moisture absorbent dispersed in an organic layer.

14. The device according to claim **12**, wherein the moisture absorbing layer is disposed between the dam and the organic encapsulation layer.

15. The device according to claim **12**, wherein the moisture-absorbent material is gradually increased in density from a side surface of the organic encapsulation layer to a side surface of the dam.

12

16. The device according to claim **11**, wherein the organic light-emitting element comprises:

- an anode electrode disposed on the substrate;
- a cathode electrode facing the anode electrode; and
- an organic layer disposed between the anode electrode and the cathode electrode, and
- a bank defining a light-emitting area of the organic light-emitting element.

17. The device according to claim **16**, wherein bank has a portion vertically overlapping the moisture absorbing layer and the organic layer.

18. The device according to claim **12**, wherein the moisture absorbing layer is disposed closer to the dam than the organic encapsulation layer.

19. The device according to claim **11**, wherein the moisture absorbing layer has a tapered side surface at an acute angle.

20. The device according to claim **11**, wherein the organic encapsulation layer has an inversely tapered side surface at an obtuse angle.

* * * * *

专利名称(译)	有机发光装置和有机发光显示装置		
公开(公告)号	US10541381	公开(公告)日	2020-01-21
申请号	US16/190239	申请日	2018-11-14
[标]申请(专利权)人(译)	乐金显示有限公司		
申请(专利权)人(译)	LG DISPLAY CO. , LTD.		
当前申请(专利权)人(译)	LG DISPLAY CO. , LTD.		
[标]发明人	PARK JOON WON KANG MOO CHAN		
发明人	PARK, JOON-WON KANG, MOO-CHAN		
IPC分类号	H01L51/52 H01L27/32		
CPC分类号	H01L51/5259 H01L51/5253 H01L27/3246 H01L27/3244 H01L51/5256 H01L2251/5346		
审查员(译)	HUYNH , ANDY		
优先权	1020170156596 2017-11-22 KR		
其他公开文献	US20190157618A1		
外部链接	Espacenet		

摘要(译)

公开了一种能够提高其可靠性的有机发光装置和有机发光显示装置。有机发光装置或有机发光显示装置包括设置在发光元件上的有机封装层，并且有机封装层包括设置在无机封装层上的第一有机封装层和第二有机封装层。设置为围绕第一有机封装层并包括吸湿材料。这样，可以实现成本降低并且防止湿气或氧气从外部引入有机发光装置的侧面。

